

## Farnsworth Television & Radio Corp.

**Model:** BT600

**Chassis:**

**Year:** Pre April 1941

**Power:**

**Circuit:**

**IF:**

**Tubes:**

**Bands:**

### Resources

[Riders Volume 12 - FARNSWORTH 12-11](#)

[Riders Volume 12 - FARNSWORTH 12-12](#)

FARNSWORTH TELEV. & RADIO CORP

**BK602,**  
**MODELS BT600, BC601,**  
**BK6025, BT600X, BC601X,**  
**BK602X, BK6025X**

1		2		3		4		5		6	
VOLTAGE	RESISTANCE	VOLTAGE	RESISTANCE	VOLTAGE	RESISTANCE	VOLTAGE	RESISTANCE	VOLTAGE	RESISTANCE	VOLTAGE	RESISTANCE
0	0	0	0	0	0	0	0	0	0	0	0
1	10	1	100	1	100	1	100	1	100	1	100
2	100	2	1000	2	1000	2	1000	2	1000	2	1000
3	1000	3	10000	3	10000	3	10000	3	10000	3	10000
4	OPEN	4	OPEN	4	OPEN	4	OPEN	4	OPEN	4	OPEN
5	250 Ω	5	250 Ω	5	250 Ω	5	250 Ω	5	250 Ω	5	250 Ω
6	500 Ω	6	500 Ω	6	500 Ω	6	500 Ω	6	500 Ω	6	500 Ω
7	1000 Ω	7	1000 Ω	7	1000 Ω	7	1000 Ω	7	1000 Ω	7	1000 Ω
8	10000 Ω	8	10000 Ω	8	10000 Ω	8	10000 Ω	8	10000 Ω	8	10000 Ω
9	100000 Ω	9	100000 Ω	9	100000 Ω	9	100000 Ω	9	100000 Ω	9	100000 Ω
0	1000000 Ω	0	1000000 Ω	0	1000000 Ω	0	1000000 Ω	0	1000000 Ω	0	1000000 Ω

**BOTTOM VIEW OF SOCKETS:**

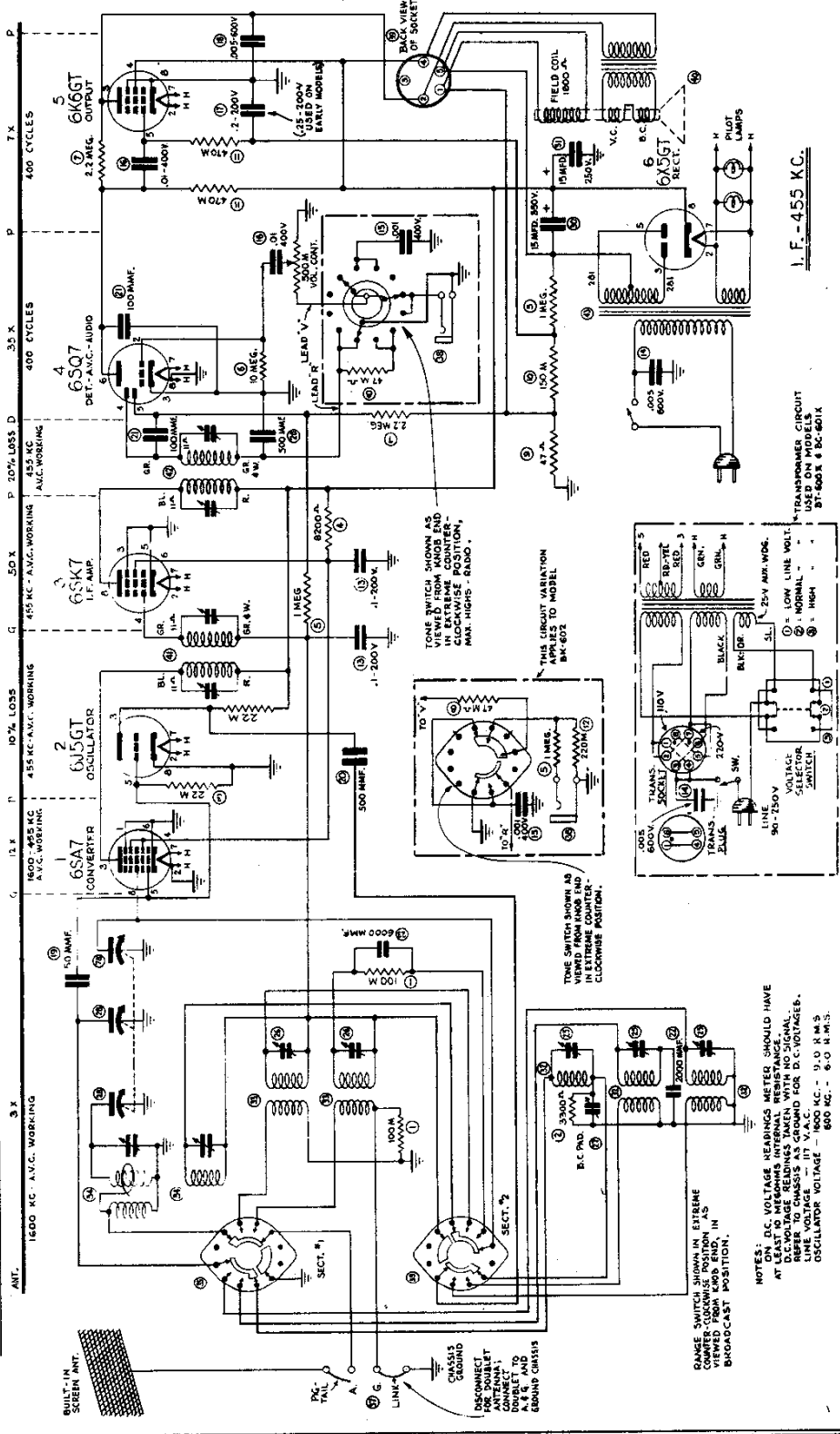

I.F. - 455 KC.

\* TRANSFORMER CIRCUIT USED ON MODELS BT-600 & BC-601X

TO NEUTRAL POSITION AS SHOWN IN EXTREME COUNTER-CLOCKWISE POSITION, MAX. HIGHS - RADIO.

THIS CIRCUIT VARIATION VIEWED FROM KNOB END BK-602

TO NEUTRAL POSITION AS SHOWN IN EXTREME COUNTER-CLOCKWISE POSITION.

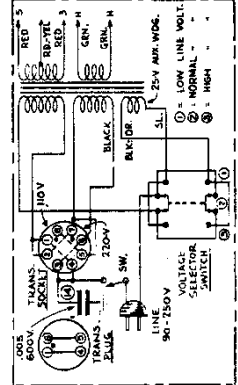

NOTES:  
 ON D.C. VOLTAGE READINGS METER SHOULD HAVE AT LEAST 10 MEGOHM INTERNAL RESISTANCE.  
 REFER TO CHASSIS AS GROUND FOR D.C. VOLTAGES.  
 LINE VOLTAGE - IN V.A.C. POS. - 110 V.M.S.  
 OSCILLATOR TUNING - 800 KC. - 6.0 M.M.S.

MODELS BT600, BC601, BK6025, BT600X, BC601X, BK602X, BK6025X BK602, FARNSWORTH TELEV. & RADIO CORP.

STRINGING DIAGRAM

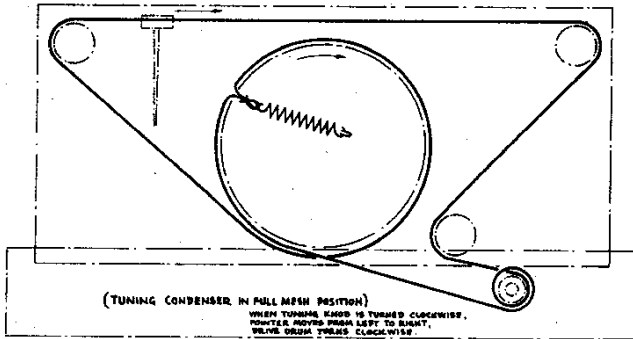

CHASSIS LAYOUT

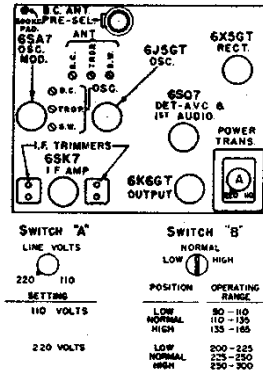

TABULATION FOR ALIGNMENT

STEPS	IN SERIES WITH ANTENNA	SET GENERATOR AT	SET GANG AT	ADJUST	LOCATED	TO OBTAIN
1.	SET VOLUME AND TONE CONTROLS AT MAXIMUM					
2.	B.C. 250 MMFD.	455 Kc.	NOTE A	2ND I.F. TRIMMERS	TOP OF I.F. TRANS.	MAX. OUTPUT
3.				1ST I.F. TRIMMERS		
4.						
5.		1900 Kc.		Osc. B.C. TRIMMER	SEE FIG.	MAXIMUM OUTPUT
6.		1500 Kc.	NOTE B	R.F. B.C. TRIMMER PRESELECTOR TRIMMER		
7.		600 Kc.		600 Kc. PAD		
8.		RECHECK 1500 Kc.				
9.	TROPICAL BAND 400 OHMS	7.0	NOTE A	Osc. POLICE TRIMMER*		
10.		6.0	NOTE B	R.F. POLICE TRIMMER**		
11.	CHECK 2.2 Mc.					
12.	S.W. 400 OHMS	22.0 Mc.	NOTE A	Osc. S.W. TRIMMER*		
13.		18.0 Mc.	NOTE B	R.F.S.W. TRIMMER**		
14.	CHECK 6 AND 10 Mc.		NOTE A. SET GANG AT MINIMUM. NOTE B. STRONGEST SIGNAL AND ROCK GANG.			

\* TIGHTEN OSCILLATOR TRIMMER SCREW FOR MAXIMUM CAPACITY, THEN UNSCREW UNTIL SECOND PEAK IS SECURED.

\*\* TIGHTEN R.F. TRIMMER SCREW FOR MAXIMUM CAPACITY, THEN UNSCREW UNTIL FIRST PEAK IS SECURED.