

Hallicrafters, Inc.

Model: S-20

Chassis:

Year: Pre 1945

Power:

Circuit:

IF:

Tubes:

Bands:

Resources

[Riders Volume 14 - HALLICRAFTERS 14-1](#)

[Riders Volume 14 - HALLICRAFTERS 14-2](#)

[Riders Volume 14 - HALLICRAFTERS 14-3](#)

THE HALLICRAFTERS CO.

SCHEMATIC DIAGRAM — SKY CHAMPION — MODEL S-20

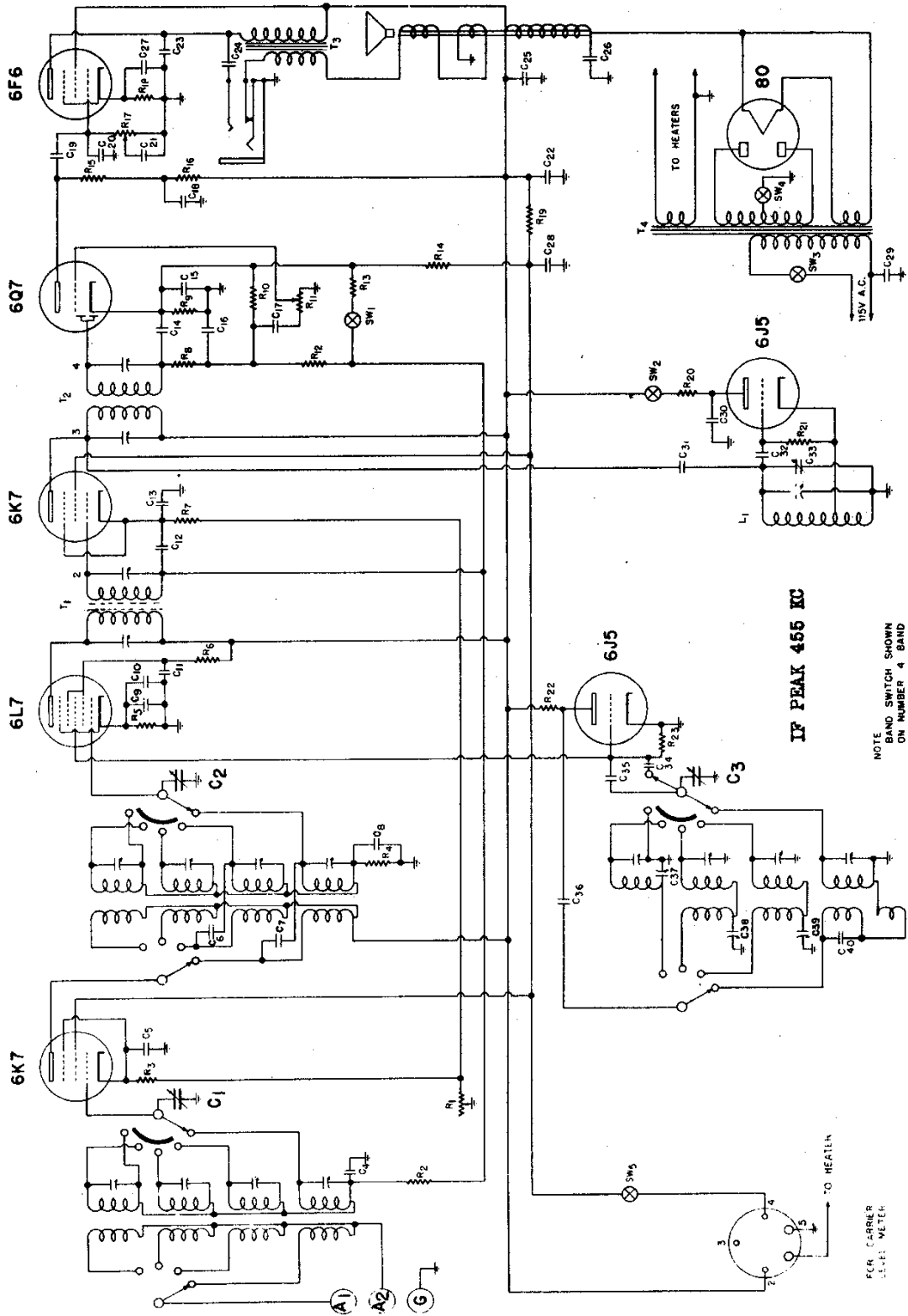

IF PEAK 455 KC

NOTE
BAND SWITCH SHOWN
ON NUMBER 4 BAND

FOR CARRIER
LEVEL METER

MODEL S-20

THE HALLICRAFTERS CO.

No.	OHMS	WATTAGE	PARTS No.	NO.	CAPACITY	TYPE	VOLTAGE	PARTS No.
1	10,000	R. F. GAIN	25-029	C1	408 MMFD	MAIN	200	48-022
2	100,000	1/3	20-093	2		TUNING	200	41-004
3	100,350	"	20-120	3	.05 MFD	"	200	41-004
4	100,000	"	22-125	5	.05 MFD	"	200	40-021
5	30,600	1/3	22-075	6	25	MICA	200	40-024
6	30,300	"	20-071	7	.05 MFD	"	200	41-004
7	20,000	"	20-072	8	.002	"	200	40-013
8	20,000	"	20-021	9	.05	"	200	41-004
9	250,000	A. F. GAIN	25-031	11	.05	"	200	41-005
10	500,000	1/3	20-108	12	.05	"	200	41-004
11	1,000,000	"	20-009	13	.02	"	200	41-002
12	25,000	1	20-073	14	100 MMFD	"	200	40-007
13	100,000	1/3	20-033	15	.1	MFD	200	41-006
14	100,000	"	20-084	16	100 MMFD	"	200	40-007
15	500,000	"	25-018	17	.05 MFD	"	200	41-007
16	500,000	500,000 TONE CONTROL	20-025	18	.1	"	200	41-007
17	20,000	"	20-073	19	.05	"	400	41-005
18	25,000	"	20-073	20	.00025"	"	400	40-024
19	100,000	1/3	20-061	21	.01	"	200	41-000
20	10,000	1	20-061	22	.01	"	400	41-007
21	50,000	1/3	20-084	23	.01	"	500	45-002
22				24	.01	"	500	45-002
23				25	8	"	450	42-021
24				26	8	"	450	41-007
25				27	10	"	25	41-001
26				28	.1	"	400	41-001
27				29	.01	"	400	41-001
28				30	.01	"	400	41-001
29				31	1	MMFD TWISTED PAIR	400	40-024
30				32	250	"	400	48-021
31				33	25	"	400	40-007
32				34	100	"	400	40-024
33				35	25	"	400	40-013
34				36	.002 MFD	PAD	44-025	44-025
35				37	1,300 MMFD	"	44-025	44-025
36				38	2,100	"	44-025	44-025
37				39	100	"	44-025	44-025
38				40	100	"	44-025	44-025
39								
40								

THE SKY-CHAMPION IS AN 8 TUBE 4 BAND SUPERHETERODYNE RECEIVER COVERING THE FOLLOWING FREQUENCIES:

SW	SWITCHES	BAND	COVERAGE
1	A. V. C. SPST	1	540 KC TO 1,800 KC
2	B. F. O. SPST	2	1.70 MC TO 5.75 MC
3	AC ON-OFF (ON TONE CONTROL)	3	5.62 MC TO 18.40 MC
4	SEND - RECEIVE SPST	4	17.00 MC TO 44.00 MC
5	EXT "M" METER (ON RF GAIN)		

SEPARATE COILS ARE USED TO COVER EACH BAND. INDUCTIVE COUPLING TO THE ANTENNA PERMITS THE MAXIMUM TRANSFER OF SIGNAL ENERGY FROM EACH SEPARATE PRIMARY TO THE PARTICULAR SECONDARY COIL IN THE CIRCUIT. THE UNUSED COILS ARE SHORTED. THE CALIBRATION ON THE MAIN DIAL IS IN KILOCYCLES ON BAND #1 AND IN MEGACYCLES ON BANDS #2,3 AND 4.

THE SEND-RECEIVE SWITCH ENABLES THE OPERATOR TO MAKE THE RECEIVER IN-OPERATIVE TEMPORARILY DURING STAND-BY PERIODS. SHOULD THE RECEIVER BE USED IN CONJUNCTION WITH A TRANSMITTER THIS FEATURE WILL PROVE VALUABLE.

ANTENNA: ON THE BACK OF THE CHASSIS WILL BE FOUND THE ANTENNA, DOUBLET AND GROUND TERMINAL STRIP. A CONVENTIONAL SINGLE WIRE ANTENNA SHOULD BE CONNECTED TO A1, AND THE JUMPER WIRE INSULATED AND G LEFT CONNECTED. A 75 FOOT PIECE OF #14 ENAMELED WIRE INSULATED AND SUSPENDED IN THE CLEAR IS RECOMMENDED FOR THIS TYPE OF ANTENNA. IF A DOUBLET ANTENNA IS USED THE TWO WIRES OF THE LEAD-IN ARE CONNECTED TO A1 AND A2 AND THE JUMPER BETWEEN A2 AND G REMOVED. A GROUND CAN BE CONNECTED TO THE G TERMINAL WITH EITHER TYPE OF ANTENNA. IT IS SUGGESTED THAT A GROUND BE LEFT OFF THE RECEIVER ONLY IF IN SO DOING THE PERFORMANCE OF THE RECEIVER IS IMPROVED. THERE ARE SO MANY DIFFERENT VERSIONS OF ANTENNA SYSTEMS THAT WE SUBMIT TO THE USER WHO WISHES TO EXPERIMENT WITH THE VARIOUS TYPES THAT HE FIRST FAMILIARIZE HIMSELF WITH THE ANTENNA SECTION OF THE A. R. L. HANDBOOK.

THE A. V. C. OR AUTOMATIC VOLUME CONTROL SWITCH PROVIDES OPTIONAL USE OF A. V. C. WHEN RECEIVING MUSIC OR VOICE SIGNALS IT IS ADVISABLE THAT THE SWITCH BE IN THE "ON" POSITION. WHEN RECEIVING CODE TRANSMISSIONS THE SWITCH SHOULD ALWAYS BE IN THE "OFF" POSITION.

THE B. F. O. SWITCH MUST BE IN THE "ON" POSITION TO OBTAIN THE NECESSARY BEAT NOTE FOR THE RECEPTION OF CODE SIGNALS. USING THE B. F. O. WILL BE HELPFUL IN LOCATING THE CARRIERS OF DISTANT AND POSSIBLY WEAK BROADCASTING STATIONS, ONCE LOCATED, THE B. F. O. SHOULD BE TURNED OFF OR THE WHISTLE WILL INTERFERE WITH RECEPTION.

THE PITCH CONTROL - WHEN THE B. F. O. IS "ON" - WILL ALLOW YOU TO VARY THE FREQUENCY OF THE RESULTANT BEAT NOTE TO ONE THAT IS MOST PLEASING TO YOU. A HEADPHONE JACK IS MOUNTED IN AN ACCESSIBLE POSITION ON THE FRONT PANEL OF THE SKY-CHAMPION. ANY TYPE OF HEADPHONES CAN BE USED BECAUSE NO DIRECT CURRENT FLOWS IN THE HEADPHONE CIRCUIT. WHEN THE PHONES ARE PLUGGED IN THE LOUD SPEAKER IS AUTOMATICALLY DISCONNECTED.

ON THE BACK OF THE CHASSIS YOU WILL FIND A SOCKET INTO WHICH YOU CAN PLUG A TYPE SM-18 CARRIER LEVEL INDICATOR. WHEN THIS METER IS USED IT WILL BE NECESSARY TO ADVANCE THE R. F. GAIN CONTROL ON THE RECEIVER AS FAR AS IT WILL GO TO THE RIGHT. DOING THIS WILL OPERATE THE SWITCH WHICH IS MOUNTED ON THE BACK OF THIS CONTROL. ADDITIONALLY THE A. V. C. SWITCH SHOULD BE IN THE "ON" POSITION TO PROPERLY CONNECT THE METER IN THE CIRCUIT. THIS METER IS AVAILABLE THROUGH THE DEALER FROM WHOM YOU PURCHASED YOUR RECEIVER.

THE TUBE-LINE-UP OF THE S-20 SKY-CHAMPION IS AS FOLLOWS:

6K7	R. F. STAGE
6L7	1ST DETECTOR - MIXER
6J56	H. F. OSCILLATOR
6K7	I. F. AMPLIFIER
6A78	2ND DETECTOR, A. V. C., 1ST STAGE OF AUDIO
6F68	AUDIO OUTPUT STAGE
6J56	BEAT FREQUENCY OSCILLATOR
80	RECTIFIER

THE HALLICRAFTERS CO.

ALIGNMENT

Set the controls as follows:

AVC and BFO switches to "OFF"; A-F and R-F gain controls to maximum volume; band switch on No. 1 band; main dial at 1800 kc or minimum capacity position.

Remove 6L7 grid cap. Connect signal generator through 0.1-mf condenser to grid of 6L7, and signal generator ground to chassis of set. Set signal generator to 455 kc. Adjust trimmers on T1 and T2 for exact resonance.

R-F Alignment

Replace the condenser in the signal generator lead with a 400-ohm resistor, connecting it to the A1 terminal on the rear of the chassis. Leave jumper between A2 and G terminals connected.

Band No. 1

Place band switch on No. 1 or broadcast band. Set generator to 1400 kc and adjust main dial to that frequency. Adjust the following trimmers for maximum signal:

- Oscillator CA
- Mixer CB
- Antenna CC

Reset generator and receiver to 600 kc and adjust the following padder for maximum signal: C37

Band No. 2

Place band switch on No.2 band. Set generator and receiver to 4 mc and adjust the following trimmers for maximum signal:

- CJ CK CL

Reset generator and receiver to 1.8 mc and resonate padder C38 for maximum signal.

Band No. 3

Place band switch on No. 3 band. Adjust generator and receiver to 14 mc and trim with CG,CH, and CL. Reset generator and receiver to 7 mc and adjust padder C39.

Band No. 4

Place band switch on No.4 band. Set generator and receiver to 40 mc and adjust CD, CE, and CF. Reset generator and receiver to 18 mc. There is no padder on the 4th band, but 18 mc should fall within 1 division with no other adjustments.

While making the above adjustments, rock the main condenser.

