

Howard Radio Co.

Model: 901AP

Chassis:

Year: Pre 1948

Power:

Circuit:

IF:

Tubes:

Bands:

Resources

Riders Volume 15 - HOWARD 15-3

Riders Volume 15 - HOWARD 15-4

HOWARD RADIO CO.

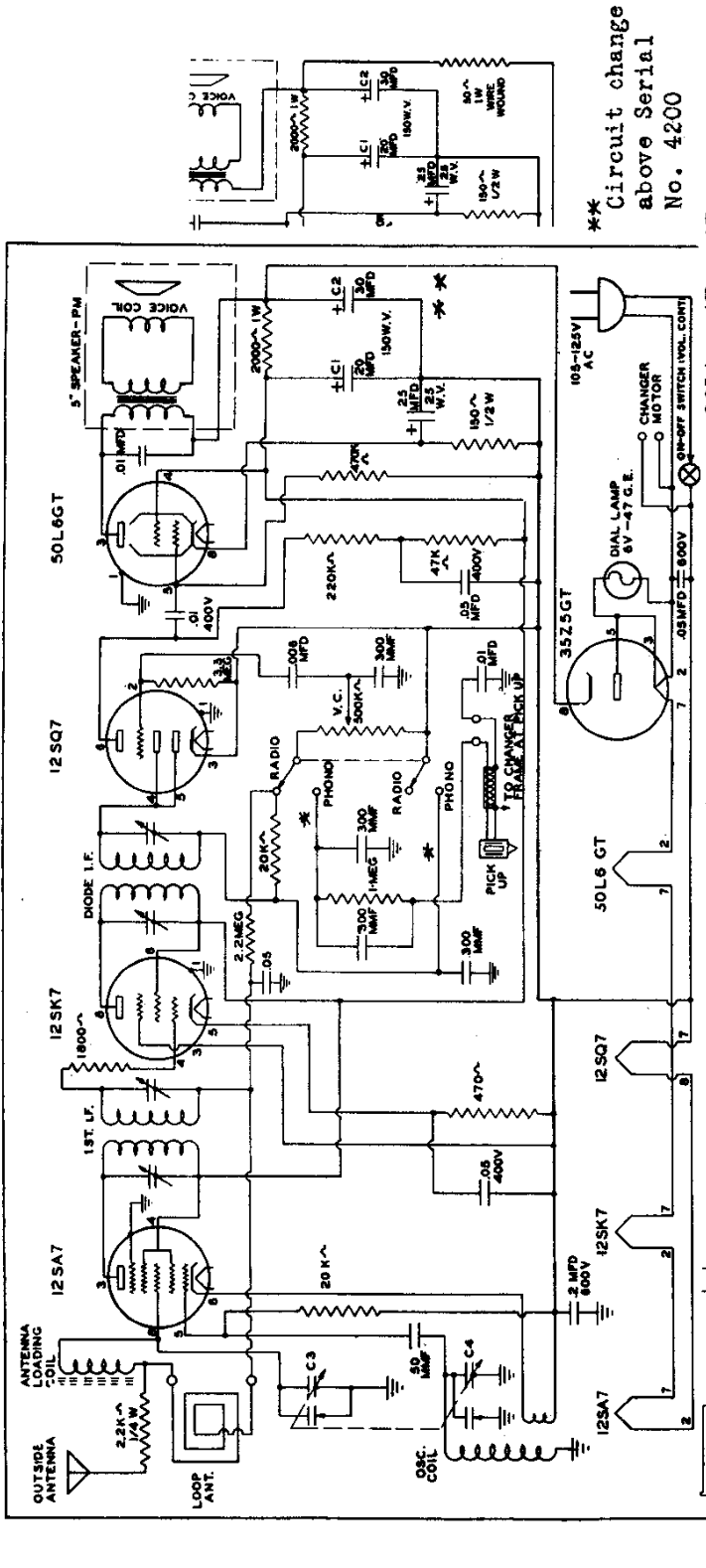

** Circuit change above Serial No. 4200

Tube	Function	Cath.	Ser. Grid	Plate
12SA7	Mixer	0	88	86
12SK7	I.F. Amp.	2.4	88	86
12SQ7	Det.	0	-	53
50L6	Output	5.8	88	115

901A - AE - AP
IF 455 KC

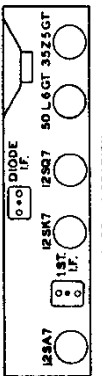

NOTE: ALL RESISTORS 1/4 W UNLESS OTHERWISE SHOWN.

*Circuit Change above Serial No. 4200

CONSUMPTION = 55 Watts ---- See label on back of chassis.
 TUNING RANGE = 540-1600 KC -- String Drive
 ANTENNA SYSTEM = Built in low impedance loop. Ant. connection only.
 SPEAKER = Permo Mag. Dynamic -- SIZE 5" -- V.C.IMP. (400CPS) 3.2 Ohms.
 POWER OUTPUT = (MAX.) 1.5 W.--UPO 1. W.
 I.F. = 455 KC -- 26 Ohms Resistance Primary and Secondary.
 VOLTAGES + OR - 20% ARE MEASURED TO B MINUS AT REAR OF AC SWITCH.

MODELS 901, 901AE, 901AH,
901AI, 901AM, 901AW
MODEL 901A
MODEL 901AP

HOWARD RADIO CO.

MODEL 901 SERIES

Part No.	DESCRIPTION	Part No.	DESCRIPTION
VC-0001	CONTROLS Volume and on-off switch	LS-0001	Dial Lamp-Bayonet Type #47
	CONDENSERS	WG-0001	Dial Window (for Plastic Cabinet)
	Tuning	WG-0002	Dial Window (for Wood Cabinets)
CV-0008	Filter, 30-30-MFD, 200 Volt	SP-0005	Tension Spring for Dial Drive Cord
CE-0001 or	Filter, 30-20-MFD, 150 Volt	HD-0001	Dial Indicator Hand (Plastic Cabinet)
CE-0003 or	Filter, 30-30-MFD, 150 Volt	HD-0002	Dial Indicator Hand (Wood Cabinet)
CE-0004 or	Filter, 25-MFD, 25 Volt this	SM-0074	Shaft-Tuning
CE-0005	used with CE-0003 or CE-0004	GR-0006	Grommet-Dial Drive Cord-Ser. #0 to #6500.
	COIL ASSEMBLIES		KNOBBS
AM-0002	Ant. Loop (for Plastic Cabinet)	KB-0003	Moulded, Ivory (Plastic Cabinet)
LA-0001	Ant. Loop (for Wood Cabinet)	KB-0004	Moulded, Walnut (Plastic Cabinet)
LO-0014	Osc. coil	KB-0005	Moulded, Brown (Wood Cabinet)
LI-0006	1st I.F. Assembly complete	CA-0038	LINE CORDS
LI-0007	Diode I.F. Assembly complete		Standard 110 Volt
	CABINETS		SOCKETS
CB-0001	Plastic, Ivory	SO-0009	Tube Sockets (Octal Wafer)
CB-0003	Plastic, Walnut	SL-0001	Dial Lamp Socket-Bayonet Type
CW-0003	Wood, Phono Model		SPEAKERS
CW-0004	Wood, Wraparound Model	SK-0001	5" Dynamic (Serial #1 to 7250)
	DIAL AND CONTROL PARTS	TO-0001	Transformer for Above
AR-0002	Calibrated Dial Plate (Plastic)	SK-0002	5" Dynamic (Above Serial #7250)
AR-0003	Calibrated Dial Plate (Wood)	TO-0002	Transformer for Above
DC-0001	Dial Drive Cord		

MODEL - 901-AP*

Part No.	DESCRIPTION	Part No.	DESCRIPTION
SK-0005	Speaker P.M. with trans.	LI-0010	1st I.F. Assembly Complete
LI-0010	1st I.F. Assembly Complete	LA-0004	Antenna Loading Coil
LA-0004	Loop Antenna Wood Cabinet	AN-0003	Loop Antenna works only with models having antenna load coil
AN-0003	Oscillator Coil	LO-0017	Oscillator Coil
LO-0017	Diode I.F. Assembly Complete	LI-0011	Diode I.F. Assembly Complete
LI-0009	Knob with set screw	SW-0005	Radio Phono Switch

*REMAINDER OF PARTS LIST SAME AS MODEL 901